



FAIRBANKS NIJHUIS™ MIXED FLOW PUMP

Material Options

Depending on the application and the type of liquid pumped, a suitable combination of materials can be selected. The most common materials for constructing the pump components are:

- Cast iron
- Ductile cast iron
- Bronze
- Aluminum bronze
- Stainless steel
- (Super) duplex stainless steel

Shaft Seals and Bearings

The selection of shaft seals and bearings for the mixed flow pump depends on the operating conditions and composition of the medium being pumped.

About Pump Curves

The Fairbanks Nijhuis mixed flow pump is available in a wide range of capacities and heads:

- Capacities: 150 - 11,000 m³/h (660 - 48,431 USGPM)
- Head: 5 - 40 mlc (16 - 131 feet)

Higher capacities and heads are available on request.

Detailed pump curves are supplied on request. We can assist you in selecting the right pump for your application in order to ensure optimum performance for the complete operating range.



Pump set with horizontal mixed flow pump

Water & Responsibility

Today, markets look for business partners who think and support in a sustainable manner.

Pentair's Fairbanks Nijhuis anticipates this need with environment-friendly products and reliable services, which help customers reduce their energy consumption and carbon footprint. The employees of Pentair are committed to contributing to a better world by having as primary objectives: preserve the environment, protect society and enable our customer's business to prosper.

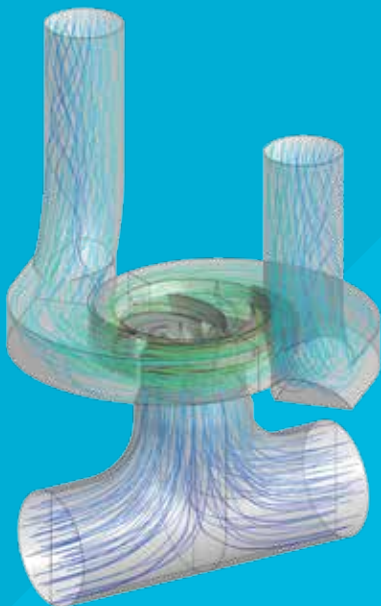

Mixed Flow Pump

Energy efficient and reliable

The energy efficient and reliable Pentair Fairbanks Nijhuis mixed flow pumps function as a compromise between radial and axial flow pumps. They operate at higher pressures than axial flow pumps while delivering higher capacities. The pumps are available in both horizontal and vertical configurations.

Applications

- Drinking water
- Sewage water
- Cooling water
- Effluent
- Irrigation
- Drainage
- Desalination

Customized Solutions

A valuable and sustainable option

System design and performance are usually dependent on the availability and configuration of suitable pumps. At Pentair, we can modify our pump designs to meet the requirements of each individual system. This results in the best overall system performance for a specific application.

Design modification can range from minor changes like reshaping the impeller to a dedicated design for a specific application. The vast experience and engineering know-how as well as advanced design software available at Pentair, ensure that new custom designs are developed in an expedient way. Hydraulic performance can be accurately predicted and all designs are subjected to structural analysis. Design verification occurs in our test facility, except for very large pumps, of which either a scale model test is performed or extensive on-site measurements can be conducted using our calibrated instrumentation. Consider a customized solution as a valuable and sustainable option when selecting your pumps.

Our Customers Benefit From

- High efficiency
- Reduced energy consumption
- Less environmental impact
- Low operating costs
- Extended service life and durability
- Low maintenance requirements

Pump Configurations

Pentair's Fairbanks Nijhuis mixed flow pumps are available in both horizontal (type HMF) and vertical (type VMF) configurations with a variety of mounting arrangements and nozzle positions to suit most pipe configurations and pumping station designs.

Horizontal configuration



Vertical configuration



PUMP OPTIONS

- The vertical pump (VMF) can be supplied with the following driver configurations:
 - with the motor mounted on the pump or independently on a higher floor level.
 - as a closed-coupled pump where the impeller is mounted directly onto the extended motorshaft.
- Optionally the pumps with larger capacities can be fitted with non-clogging pump impellers.



Features and Benefits

FEATURES

- Oversized shafts and reduction of the overhang reduces shaft deflection to a minimum. This eliminates shaft failures and increases seal and bearing life.
- For ease of maintenance, the entire rotating assembly can be removed without disturbing the casing or suction and discharge piping (back pull-out design).
- Larger mixed flow pumps in sewage systems have specially designed impellers with large ball passages. The replaceable wear rings carry solid matter away from the working face, thus reducing wear and eliminating clogging and jamming.
- Large access holes with contoured covers give easy access to the impeller.

BENEFITS

- High efficiencies and reduced energy consumption by designing the pump's BEP to customer duty point.
- Low NPSH values
- High suction lift
- Less civil works
- Low operating costs by appropriated material selections to the demanding water qualities. This includes the optional selection of duplex stainless steels.
- Space-saving vertical configurations reduce the footprint.
- Low maintenance requirements through reliable and proven pump designs.
- Back pull-out design for easy access.

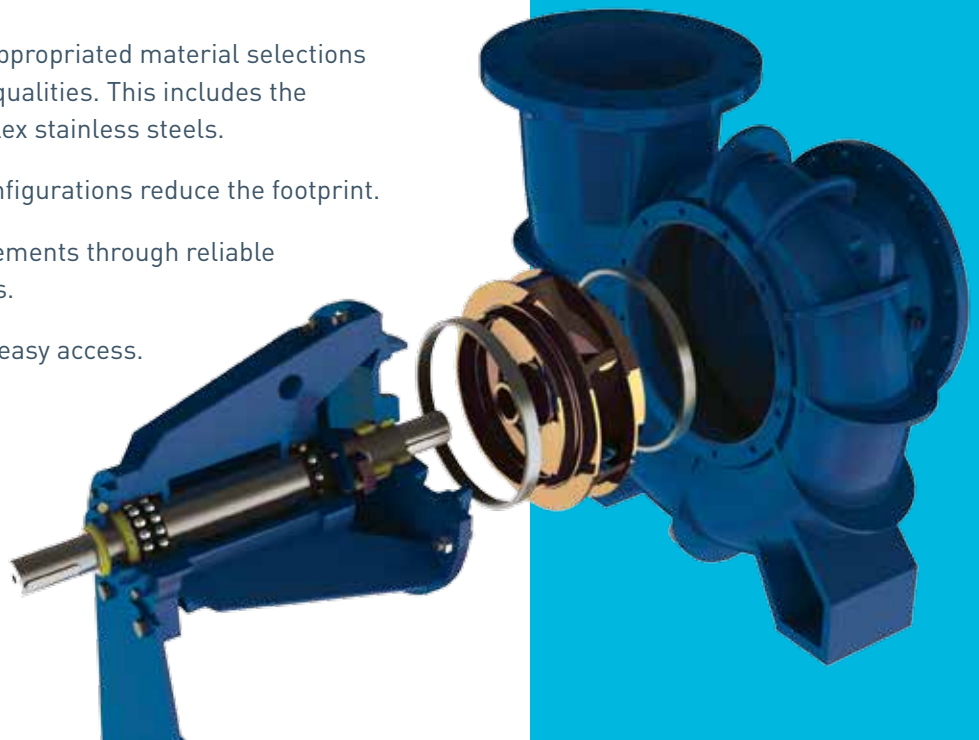
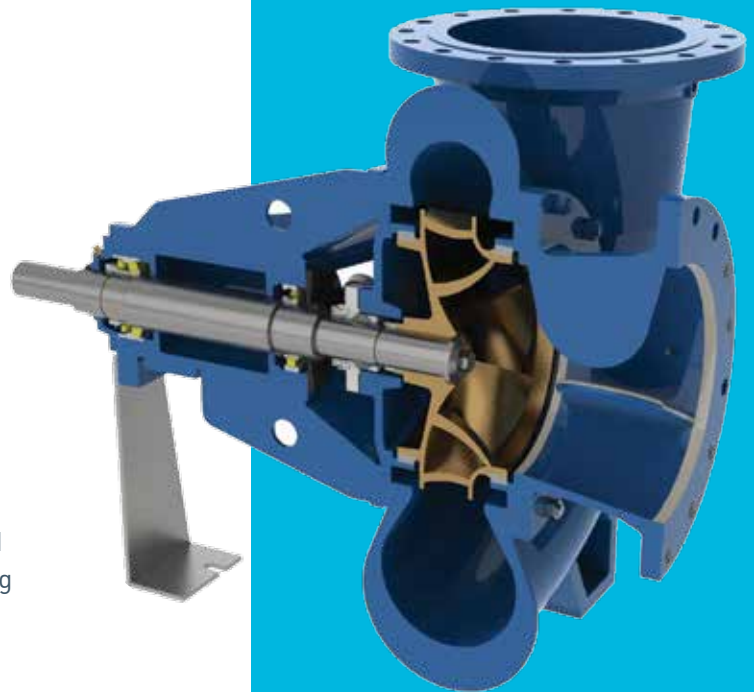



WORLDWIDE

Sales and Service Organizations

Pentair's Fairbanks Nijhuis pump line delivers high-quality products and services based on more than 100 years experience in the design, production and application of centrifugal pumps and pumping systems according to customers' specifications. In our facilities (Winterswijk, The Netherlands and Kansas, USA) our dedicated staff continuously sets the standard for product improvement based on the latest developments in the market. Using advanced computer-aided technology, we develop tailor-made pumps with the highest achievable efficiencies. After-sales service is offered, supported by a global network of service centers, staffed by experts in state-of-the-art pump technology. Customers who ordered pumps from Fairbanks Nijhuis decades ago are still regular customers, which indicate they trust and rely on our pumps and related services. The quality assurance program is certified by Lloyd's according to ISO 9001 and guarantees that products and services meet all international standards. Our Fairbanks Nijhuis line embraces the values of sustainability, openness, reliability, and social responsibility within the company and especially in cooperation with customers, suppliers and the world around us.

Pentair's

Global Solutions Areas

FILTRATION & PROCESSING SOLUTIONS

Our advanced filtration, separation, treatment and quality control of water and other fluids provides solutions for restaurants and breweries, local municipalities and corporate office buildings.

FLOW MANAGEMENT SOLUTIONS

We enable the control, isolation and movements of fluids, gases and other media – solutions that help maintain crucial operations in industries as diverse as refineries, agriculture and municipal infrastructure.

EQUIPMENT PROTECTION SOLUTIONS

We create solutions that enclose, protect and cool essential electrical and electronic equipment to help keep vital systems running.

THERMAL MANAGEMENT SOLUTIONS

We help our customers manage heat requirements to maintain critical processes and provide greater control over a full array of thermal management demands.



THE NETHERLANDS
NIJHUIS POMPEN BV
PARALLELWEG 4
7102 DE WINTERSWIJK
T +31 (0)543 547474
INFO.NIJHUIS@PENTAIR.COM

SERVICES DIVISIONS
WATERLAND 4
1948 RK BEVERWIJK
T +31 (0)251 270270

STOELERIJ 14
4762 AN ZEVENBERGEN
T +31 (0)168 370 950

HANDELSWEG 23A
9482 WG TYNAARLO
T +31 (0)592 541 085

USA
KANSAS CITY FACILITY
3601 FAIRBANKS AVENUE
KANSAS CITY, KANSAS 66106 USA

913-371-5000
FAX: 913-748-4025

www.FairbanksNijhuis.com